



# GLOBAL OPTIMIZATION OF INTEGRATED PHOTOVOLTAIC SYSTEM FOR LOW ELECTRICITY COST

## OBJECTIVE

A global approach to lower the cost of PV electricity via highly competitive PV technologies.

## GOAL

- GOPV aims to demonstrate an integrated 500 kW PV system reaching a competitive electricity cost of 0.02 €/kWh for irradiation levels of 1900 kWh/m<sup>2</sup>/year GHI in Southern Europe.

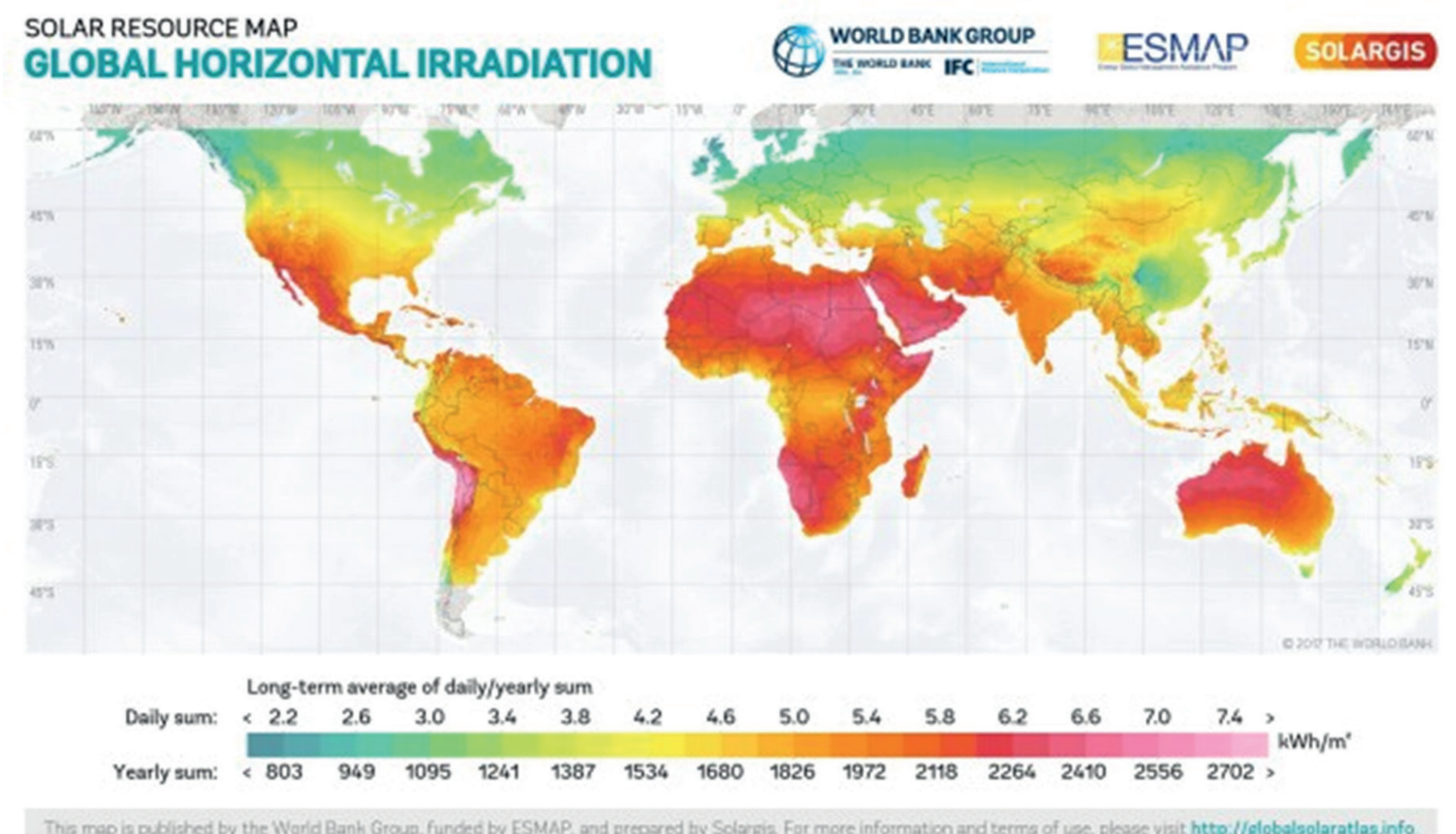

## TECHNOLOGY

PV plant cost element	GOPV developed component	Main characteristics	Targeted cost	Targeted lifetime
Module	Bifacial HJT modules	400W + bifaciality ≥ 90%	0,22€/W	35 years
Tracker	1 axis tracker	Built with alternative materials to hot dip galvanized Steel	0,11€/W	35 years
Inverter	Current source string inverter	125 kVA + Energy efficiency ≥ 99%	0,05€/W	20 years
O&M	Advanced fault detection & diagnostics tool	Energy availability ≥ 99.5%	10k€/MW/Year	-

Module, inverter, tracker and O&M innovations to enable substantial enhancement of performance and reduction of cost.

## STEPWISE DEVELOPMENT PLAN UP TO LARGE SCALE DEMONSTRATOR

- Multi busbar stringer with gluing technology up to 8 ribbons
- Optimization of the deposition process of ARGICOAT antireflective and antisoling coating for industrial use up to 30x30 cm
- Low Tracker made in Weathering Steel to reduce LCA and LCOE; designed with the support of CFD modelling to value wind actions and shaped to optimize bifacial gain
- Predictive maintenance tool to increase Performance Ratio and Energy Availability while reducing O&M costs
- 72 cells HeteroJunction glass-glass frameless bifacial module up to 400W power

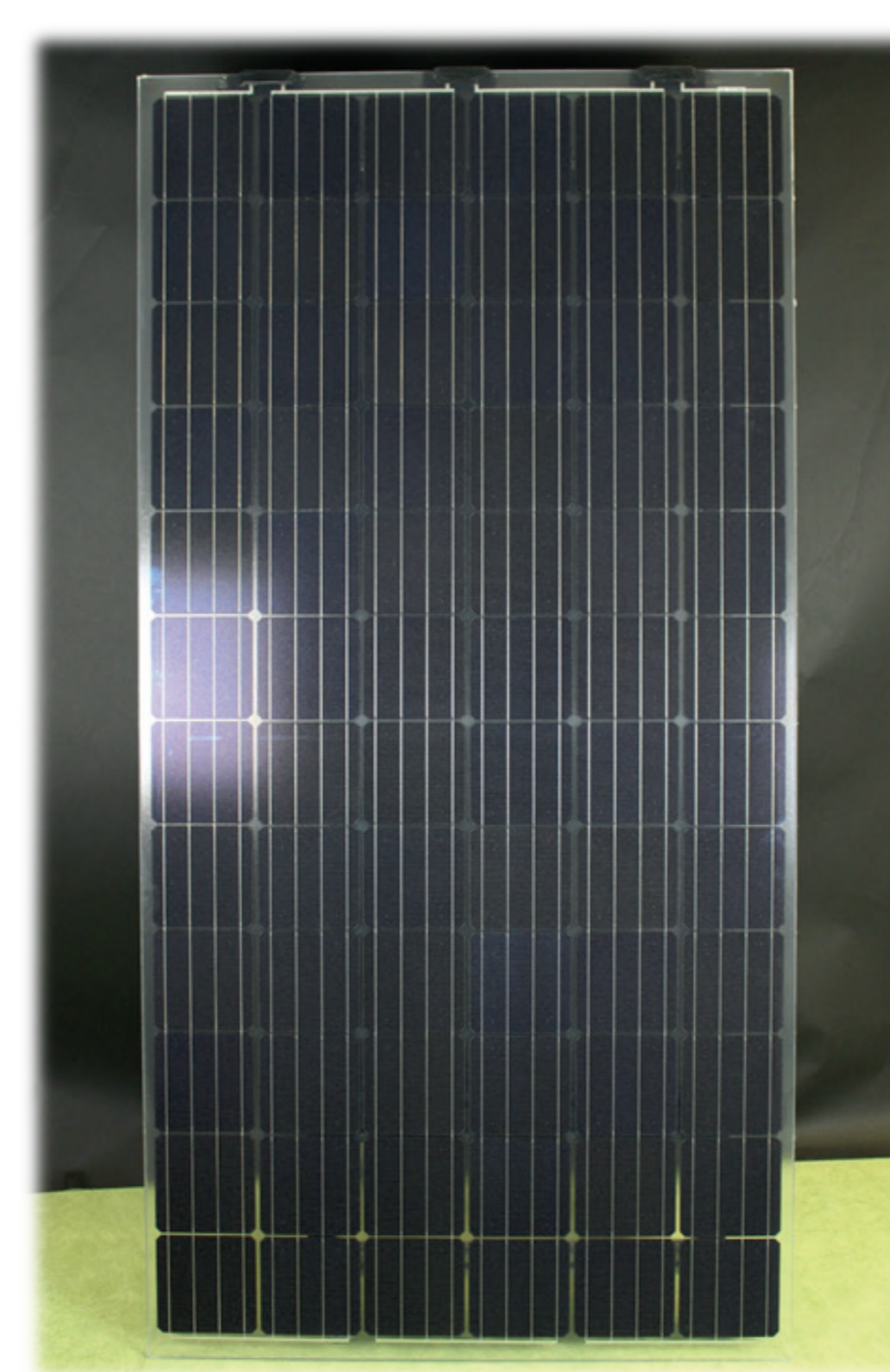
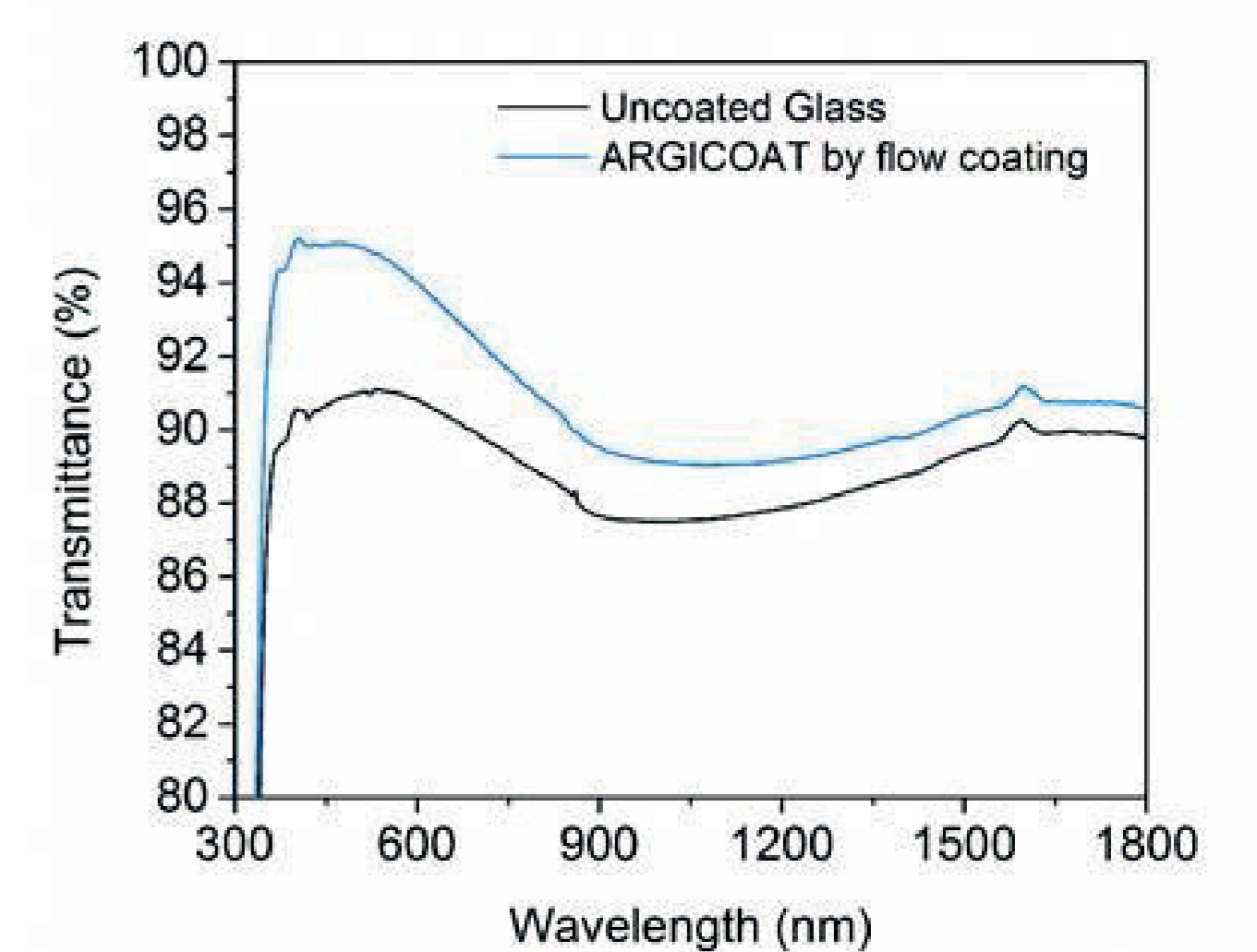
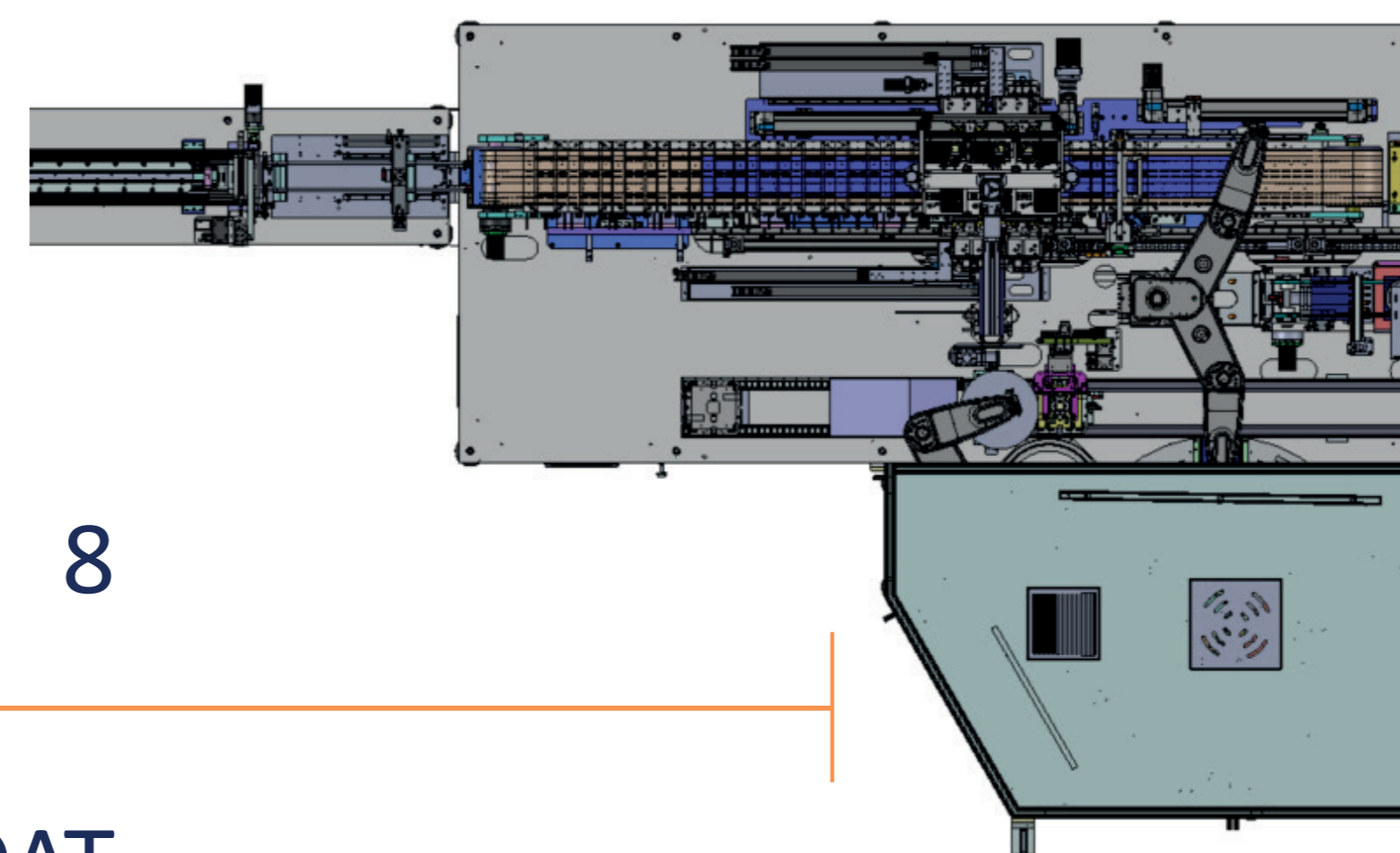

## PARTNERS

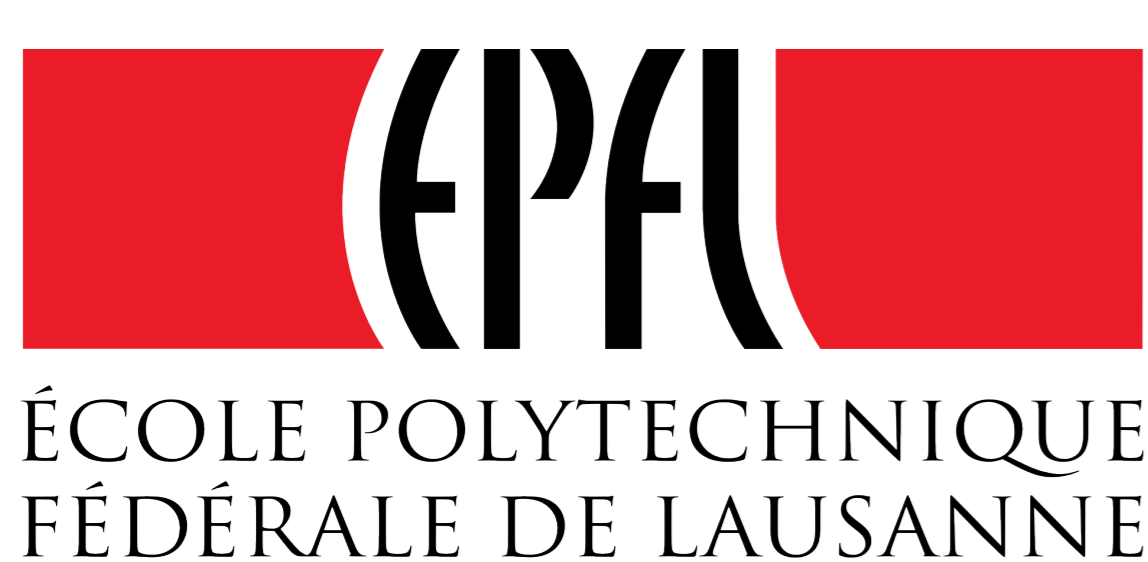

Started in April 2018 for 4 years – European Commission grant of 9,8M EUR



This project has received funding from the European Union's Horizon 2020 research and innovation programme under grant agreement No 792059